



Instrument Transformers, Inc.

a division of GE Multilin



# Capacitor Trip Device With Battery Back-Up Model CTDB-6



LISTED  
IND. CONT. EQUIP.



FILE NO.  
E103039

### APPLICATION:

Provides a source of energy for circuit breaker and switch trip coil operation during a loss of AC control voltage.

Tripping power is available immediately upon energization before capacitors charged.

### FREQUENCY:

50/ 60 Hz.o 400Hz.

### NORMAL INPUT:

120/240 Volts ac.



### Specifications

Max. Input Voltage:  
2 Va burden continuous  
2 Va burden continuous

Available Energy:  
CTDB-6-120: 64 joules  
CTDB-6-240: 57 joules

Normal Output Voltage:  
CTDB-6-120: 169 Vdc  
CTD-6-240: 340Vdc

Capacitance:  
CTDB-6-120: 4500 uF ± 20%  
CTDB-6-240: 990 uF± 20%

Operating temperature range:  
-30°C to 60°C

Storage temp range:  
-50°C to 80°C

Short Circuit Protection:  
Continuous

Mounting:  
Vertical or horizontal

Input Surge Protection:  
MOV protected to 65 joules pulse surge

• The Automatic Charging Trip Device (CTDB-6) is used to trip circuit breakers and lock out relay when a battery or standby source is not available to provide circuit breaker trip power. The CTDB-6 converts ac bus voltage to dc voltage and stores enough energy to operate a lock out relay or trip a circuit breaker, often more than once. The CTDB-6, when fully charged, will maintain a charge for a minimum of 3 days after the ac power has been interrupted. In normal operation, the batteries are trickle charged from the ac voltage source. Voltage is available from the ac power supply for tripping immediately upon ac voltage power up. Capacitors do not need to be charged to have tripping voltage available on the output of the device, this is because the output is automatically fed from the full wave bridge rectified ac signal or the charged capacitors, which ever is greater. Capacitor charge current is limited to protect the control power system from a large current in-rush. this feature allows the use of many CTDB-6 units from the same control power voltage source without coordination problems. Additionally, the CTDB-6 is self-protected from short circuit damage on the output. Batteries: 4 - rechargeable 1.2 volt Ni-Cad Cells \* Electrical specifications are at 25 deg C

**Notice:** Ac power must be applied continually for minimum of 2 hours before the CTDB-6 is capable of developing full charge on the capacitors with a sustained interruption in ac input. It is highly recommended that batteries be fully charged before installing into the CTDB-6. The CTDB-6 is designed to trickle charge the batteries to hold a charge indefinitely, but the CTDB-6 trickle charge circuit can take as long as 48 hours to charge batteries that are completely discharged. The CTDB-6 capacitor trip device is not intended for use as a dc power supply. The self protecting feature of the unit will severely limit the continuous output current and voltage.

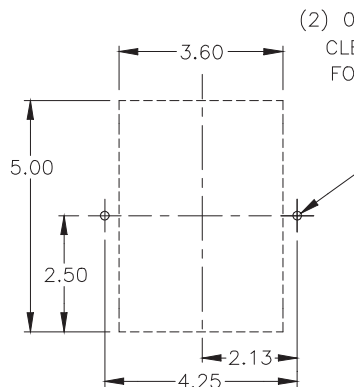
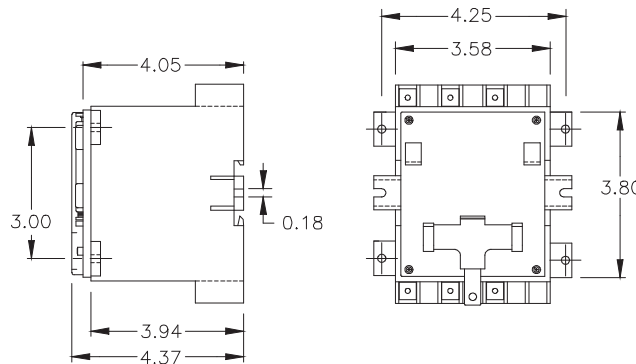
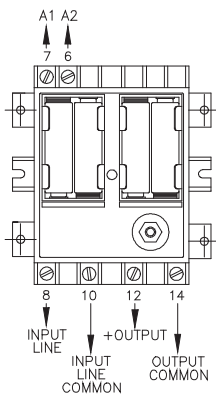

PANEL MOUNTING LAYOUT

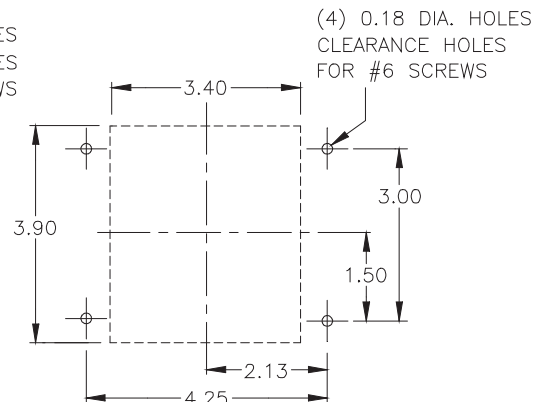

DOOR MOUNTING LAYOUT

Servicing: See Next Page

**Danger!**  
Lethal voltages are present qualified persons should install, operate, and service this device.

## \* Battery Disposal Information:



This product may contain portable batteries. In accordance with the European Directive 2006/66/EC, batteries and accumulators are marked with the crossed out wheeled bin, which indicates that they cannot be disposed of as unsorted municipal waste in the European Union. The marking may also include a chemical symbol (Pb for Lead, Hg for Mercury, and Cd for Cadmium) indicating that the battery contains substances classified as hazardous by the European Commission. Users of batteries must use the collection points available to customers for the return, recycling, and treatment of batteries. Customer participation is important to minimize the negative effects of batteries to the environment and sustain available natural resources. For more information see [www.eeerohsinfo.com](http://www.eeerohsinfo.com).

## Operation:

Nominal ac volts is applied across terminals #8 and #10. This voltage is full wave bridge rectified and applied across the trip capacitors producing a steady state output trip voltage. The charge stored in these capacitor is available across terminals # 12 (positive) and #14 (negative).

A battery operated oscillator circuit will maintain the charge on the capacitors for a minimum period of 3 days provided that terminals #6 is connected to terminal #7 and the batteries are fully charged. Terminals #6 and #7 can be connected with a normally open relay contact operated by the ac power supply so that the oscillator is activated upon power failure. The batteries charge continuously when power applied to the circuit. Since batteries can take up to 48 hours to charge while installed in the CTDB-6, we recommended that fully charged batteries be installed in the CTDB-6 unit prior to putting the unit into service.

A push button and led indicator are used to determine if the CTDB-6 is operationally ready. When the button on the front panel is pushed, the LED will illuminate if the Capacitor has minimum charge of 90 Vdc for the CTDB-6-120, and 200 Vdc for the CTDB-6-240. The push button should only be pressed long enough to observe the illumination of the LED. The push button and LED does not indicate the present of ac voltage.

### Servicing:

Never remove the clear plastic cover without this discharge procedure:

1. Remove the 120 Vac control power.
2. Remove the jumper, or open the relay contact, across terminals #6 and #7.
3. Discharge the capacitor trip device. (A 5 watt resistor of approximately 500 ohms across Terminal #12 and #14 can be used for this purpose)

Replace the 4 rechargeable 1.2 Volt Ni-Cad Cells according the battery manufactures recommended schedule. Never attempt to change batteries without following the discharge produce. Battery terminals voltages are not isolated from the control and trip power.

The CTDB-6 unit will recharge itself if terminals #6 and #7 remain shorted! Follow the discharge procedure prior to any service or maintenance of the CTDB-6 unit or trip system.

## CTDB-6 Panel Layout

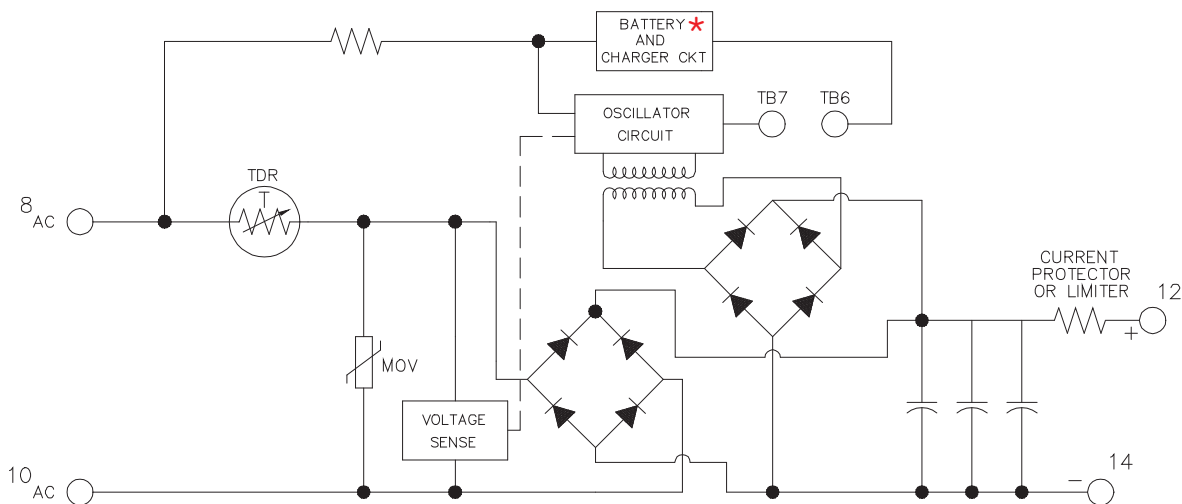

### USA, Canada, Asia, Latin America

Tel: +1-800-547-8629

Fax: +1-905-201-2455

e-mail: [sales.multilin@ge.com](mailto:sales.multilin@ge.com)

### Europe, Middle East, Africa

Tel: +34-94-485-88-00

Fax: +34-94-485-88-45

e-mail: [gmultilin.euro@ge.com](mailto:gmultilin.euro@ge.com)